



- Polyamide hand held enclosure for MCR- and automation engineering
- Ergonomic enclosure shape
- Version with or without display opening
- Prepared for acceptance of keypads/silicone switch mats
- Optional EMC version with internal coating and EMC seal

Included in delivery

Double-skinned enclosure with top and base unit, each with fixing domes, fastening and enclosure screws.
Open version incl. display screen and punched seal.

Technical data

Material:

Polyamide

Ingress protection:

IP 65, EN 60529

Disruptive strength:

> 7 Joule to DIN 50014

Surface resistance:

10^{12} Ohm to DIN 53482

Flammability:

V2 to UL 94

Temperature range:

-40°C to +60°C

Colour:

black-grey, similar to RAL 7021

Beluga 180/220

Programme range

Enclosure type	Order No.	Version	Dimensions W x L x H (mm)	Weight (kg)
Beluga 180 O	27.02 02 00	open	106/75 x 187 x 50	0.16
Beluga 180 G	27.02 02 01	closed	106/75 x 187 x 50	0.17
Beluga 220 O	27.02 04 00	open	116/85 x 220 x 51	0.20
Beluga 220 G	27.02 04 01	closed	116/85 x 220 x 51	0.21

Accessories

Hook set without magnet	27.02 00 80
Hook set with magnet	27.02 00 81
Keypad FT 180b, 15 keys, Matrix printed (B 180)	82.10 00 03
Keypad FT 180ge, 12 keys, Matrix with plug-in unit (B 180)	82.10 00 07
Keypad FT 180e, 15 keys, Matrix with plug-in unit (B 180)	82.10 00 04
Keypad FT 220b, 18 keys, Matrix printed (B 220)	82.10 00 05
Keypad FT 220e, 18 keys, Matrix with plug-in unit (B 220)	82.10 00 06
Display fixing set (B 180)	27.01 06 80
Display fixing set (B 220)	27.02 04 82
Cable gland with bending protection M 16 x 1,5	08.10 01 16
Cable gland with bending protection M 20 x 1,5	08.10 01 20
Hand strap	27.02 00 83
Spare screws	27.02 00 82
Spare display screen set (B 180)	27.01 06 88
Spare display screen set (B 220)	27.02 04 83
Battery compartment	27.02 00 85
Battery holder for 4 round cells for battery compartment	27.02 00 86
Battery holder for 9 V battery for battery compartment	27.02 00 87
Wall fixing for hook set	27.02 00 84
Scratch resistant display screen	on request
Push-button and switches see page 55 - 60	on request



Electromechanical components

On request, we offer the enclosures ready equipped with electromechanical components such as emergency stop button, confirm keys, hand wheel, step switch, display.

Components mounting options

Component options	Type B180 O	Type B180 G	Type B220 O	Type B220 G
Display max. view area 42 x 65 mm max. mounting dimensions 56,4 x 74 mm or 54 x 80 mm	•			
Display max. view area 49 x 78 mm max. mounting dimensions 71,5 x 84 mm or 70,5 x 86 mm			•	
Emergency stop button	•	•	•	•
Confirm key	•	•	•	•
Hand wheel		•		•
Step switch		•		•
Joy stick	•		•	
Cable outlet up to M 16	•	•	•	•
Cable outlet up to M 20			•	•
1st board (main board)	•	•	•	•
Other boards	•	•	•	•

Dimensions



Type	Version	Order No.
Beluga 180 O	open	27.02 02 00
Beluga 180 G	closed	27.00 02 01

(max. PCB size of displays ca. 74 x 56.4 mm or 80 x 54 mm)

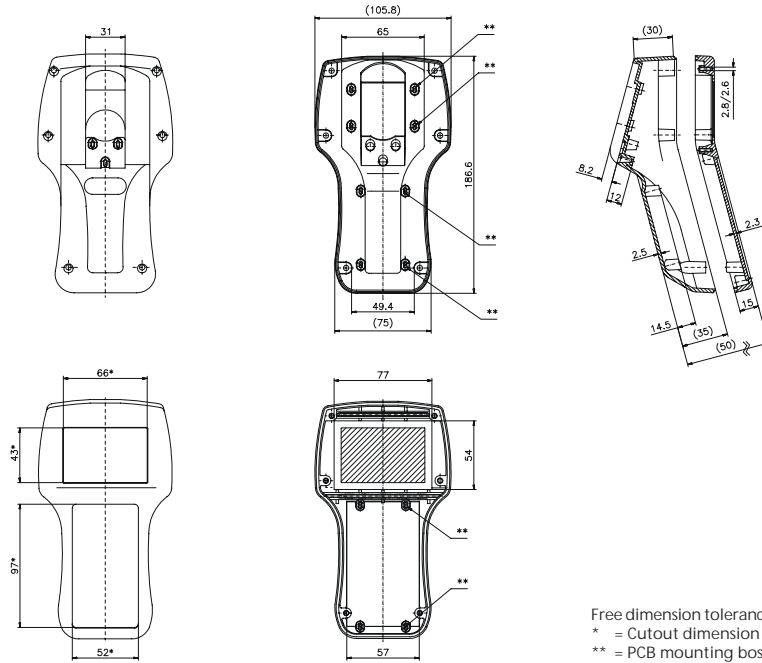

Free dimension tolerance to DIN 16901-130
 * = Cutout dimension
 ** = PCB mounting boss (screw 3 x 8)



Type	Version	Order No.
Beluga 220 O	open	27.02 04 00
Beluga 220 G	closed	27.02 04 01

(max. PCB size of displays ca. 84 x 71.5 mm or 86 x 70.5 mm)

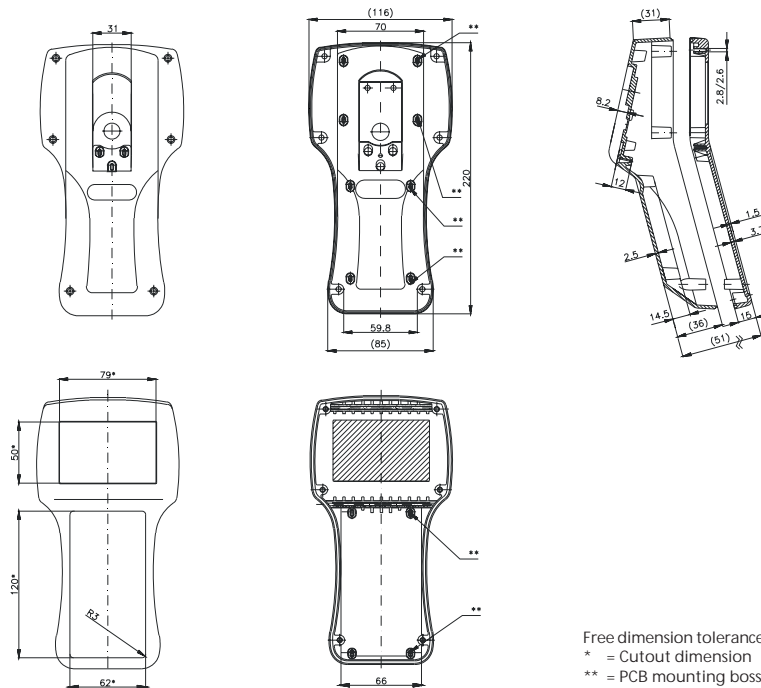

Free dimension tolerance to DIN 16901-130
 * = Cutout dimension
 ** = PCB mounting boss (screw 3 x 8)

Accessories



Membrane keypads for Beluga 180

Standard membrane keypad with 15 keys as printed version or plain. Insertion facility for custom inscription

Type	Version	Order No.
FT B180 - 15 b	Matrix printed	82.10 00 03
FT B180 - 15 e	Matrix with insertion facility	82.10 00 04

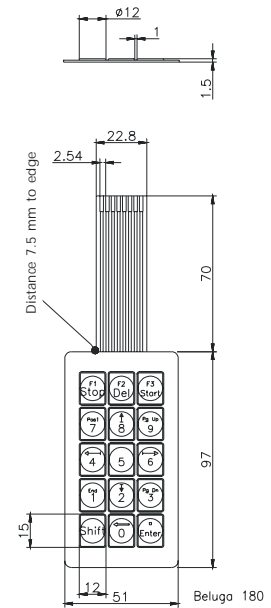
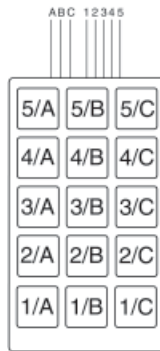

Membrane keypads for Beluga 220

Standard membrane keypad with 18 keys as printed version or plain. Insertion facility for custom inscription

Type	Version	Order No.
FT B220 - 18 b	Matrix printed	82.10 00 05
FT B220 - 18 e	Matrix with insertion facility	82.10 00 06

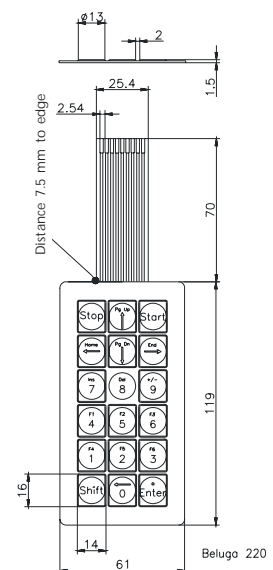
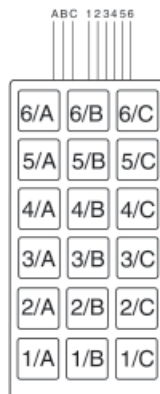

Accessories

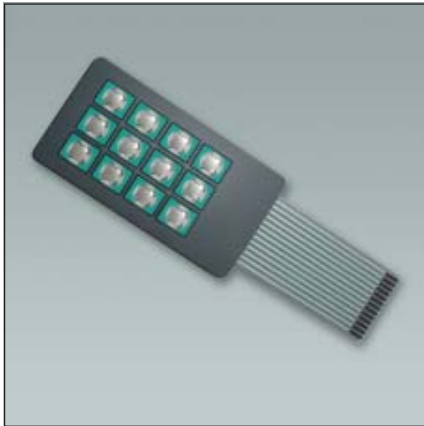

Membrane keypads for Beluga 180

Standard membrane keypad with 12 keys as plain version. Insertion facility for custom inscription

Type	Version	Order No.
FT B180 - 12 ge	common connection with insert facility	82.10 00 07

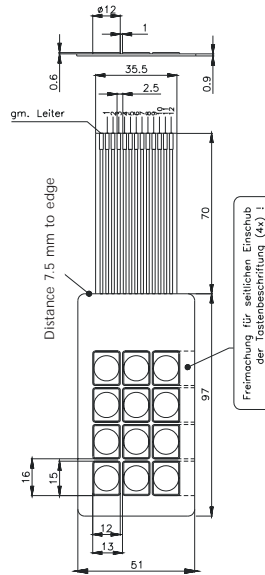

Hook set
consisting of mounted hook and fixing screws

Version	Order No.
without magnet	27.02 00 80
with magnet	27.02 00 81



Display fixing set
for variable display mounting

Version for	Order No.
Beluga 180	27.01 06 80
Beluga 220	27.02 04 82

Adhesion by version with magnet

plate thickness	force
2 mm	20 N
5 mm	30 N

Applications

